

GN 816.1 | Indexing plungers

Safety stop, steel

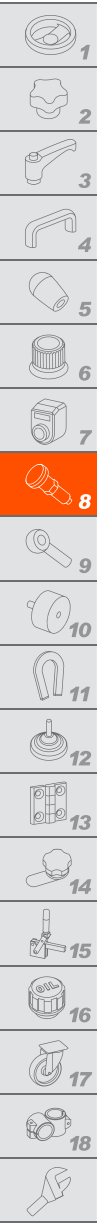

1 THREADED BODY

Zinc-plated steel.

2 PLUNGER

AISI 303 stainless steel.

3 SPRING

AISI 301 stainless steel.

4 LOCKING NUT

Zinc-plated steel.

5 KNOB AND SLEEVE

High-resilience polyamide based (PA) technopolymer, black colour, matte finish.

6 STANDARD EXECUTIONS

- **GN 816.1-A:** with knob, without locking nut.
- **GN 816.1-AK:** with knob, with locking nut.
- **GN 816.1-B:** with sleeve for operation with key, without locking nut.
- **GN 816.1-BK:** with sleeve for operation with key, with locking nut.

Key in high-resilience polyamide based (PA) technopolymer, black colour, matte finish. Zinc-plated steel hub.

Available as accessory sold separately (see table).

7 FEATURES AND APPLICATIONS

GN 816.1 indexing plungers are retracted in the rest position. By pressing the plunger inside the body and turning the knob by 90°, the plunger reaches the protruding safety position by means of the pin sliding inside a slit. The plunger returns into the original retracted position by pushing once again the knob, making it turn by 90° and releasing it.

For GN 816.1-B and GN 816.1-BK the above operations may be carried out only by means of a key (to be ordered separately).

Supplied with the technopolymer sleeve not assembled. It can be assembled eventually by a simple pressure.

8 ACCESSORIES ON REQUEST

- GN 609.5: AISI 303 stainless steel distance bushings for the assembly of the indexing plunger on thin sheets (see page 562)
- GN 816.1-10: key in high-resilience polyamide based (PA) technopolymer, black colour, matte finish. Zinc-plated steel hub. For all versions.

9 SPECIAL EXECUTIONS ON REQUEST

Indexing plungers with red clamping knob (GN 816.1-AR).

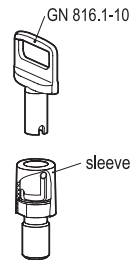

Assembly example

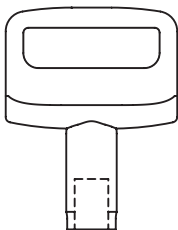
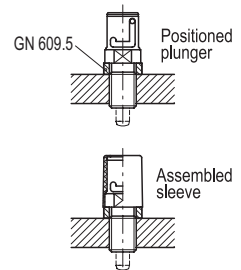

GN 816.1-10

Code	Description	⚖️
GN.39905	GN 816.1-10	5



Conversion Table 1 mm = 0.039 inch	
d1	
mm	inch
6	0.24
8	0.31

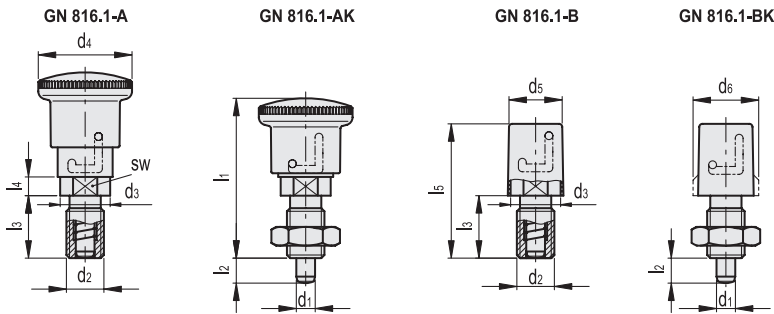

GN 816.1-A

METRIC

Code	Description	d1 Plunger -0.05 Hole +0.15 +0.07	d2	d3	d4	l1	l2	l3	l4	sw	Spring preload [N]	Spring max load [N]	⚖️
GN.39931	GN 816.1-6-M12x1.5-A	6	M12x1.5	16	28	51.5	8	20	6	14	12	27	50
GN.39941	GN 816.1-8-M16x1.5-A	8	M16x1.5	18	28	54.5	10	22	6	16	12	35	50

GN 816.1-AK

METRIC

Code	Description	d1 Plunger -0.05 Hole +0.15 +0.07	d2	d3	d4	l1	l2	l3	l4	sw	Spring preload [N]	Spring max load [N]	⚖️
GN.39932	GN 816.1-6-M12x1.5-AK	6	M12x1.5	16	28	51.5	8	20	6	14	12	27	60
GN.39942	GN 816.1-8-M16x1.5-AK	8	M16x1.5	18	28	54.5	10	22	6	16	12	35	80

GN 816.1-B

METRIC

Code	Description	d1 Plunger -0.05 Hole +0.15 +0.07	d2	d3	d5	d6	l2	l3	l4	l5	sw	Spring preload [N]	Spring max load [N]	⚖️
GN.39935	GN 816.1-6-M12x1.5-B	6	M12x1.5	16	17	-	8	20	6	43	14	12	27	40
GN.39945	GN 816.1-8-M16x1.5-B	8	M16x1.5	18	17	20	10	22	6	48	16	12	35	50

GN 816.1-BK

METRIC

Code	Description	d1 Plunger -0.05 Hole +0.15 +0.07	d2	d3	d5	d6	l2	l3	l4	l5	sw	Spring preload [N]	Spring max load [N]	⚖️
GN.39936	GN 816.1-6-M12x1.5-BK	6	M12x1.5	16	17	-	8	20	6	43	14	12	27	43
GN.39946	GN 816.1-8-M16x1.5-BK	8	M16x1.5	18	17	20	10	22	6	48	16	12	35	70